

Performance parameters of encapsulated sealing rings

This article investigates how the properties of fluoropolymer rubber seals affect the performance of seal assemblies.

By K. Yu. Zershchikov, Constanta-2, Volgograd, Russia

Operating conditions of valves and pumps vary quite widely. Polymer seals inside the devices are exposed to many external impacts, such as temperatures between -270°C and $+300^{\circ}\text{C}$, pressures between 0.01 and 100 MPa, mating surfaces reciprocal displacement speeds up to 10 m/s and aggressive fluids. The most widely used sealing materials are elastomers due to the rubber's many valuable intrinsic properties, including the abilities to maintain stable contact pressure under the seal's specific compression strain and to quickly recover the size and shape once the impact is removed. However, lack of general resistance to the variety of aggressive chemical fluids, low heat resistance and low strength combined considerably limit application of elastomers in heavy-duty equipment. Composite fluoropolymer-rubber (encapsulated)

sealing rings (FRR), demonstrating much better endurance when used with aggressive fluids, higher heat- and cold resistance, lower friction coefficient and higher elasticity, can become a good solution to the problem. However, merely having a seal, even a unique one, is not enough. It is also crucial to efficiently use its sealing properties in the seal assembly made up by the seal and the sealed surfaces. To achieve this, we should know how the seal's properties and the way it interacts with the mating surfaces affect the equipment performance. The article is to find how the properties of fluoropolymer-rubber seals are related to the performance of the seal assemblies.

Encapsulated O-rings are composite seals comprising an elastomer core enclosed in a

capsule protects the seal from degrading under high temperatures, pressures and aggressive fluids. For better heat resistance, the core should be silicone rubber (SI) or fluorinated rubber (FKM), and the capsule should be FEP or PFA fluoropolymers to make the ring more resistant to aggressive media and high temperatures.

The many experiments have shown that the sealing behavior of FRR is not identical to that of regular rubber O-rings. Rubber O-rings press the rubber into the gap to fill it, which largely depends on the groove shape, while the sealing action of encapsulated rings consists in creating a contact pressure p_c onto the mating surfaces (fig. 2). This means that FRR sealing capacity shall be assessed by the contact pressure generated as the compression strain occurs.

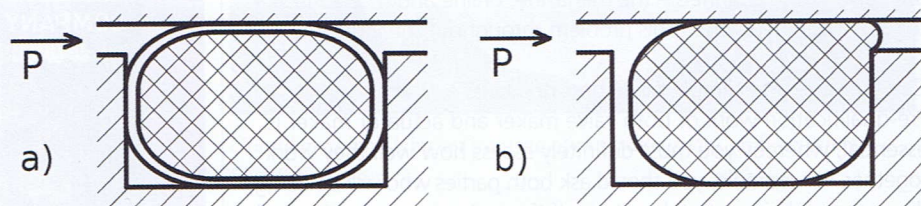
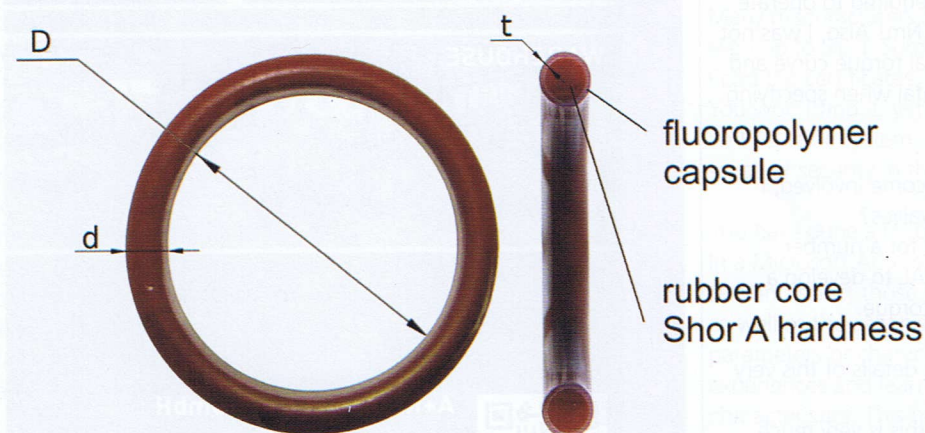

Figure 2. Sealing action of FRR (a) and rubber O-ring (b)

tight fluoropolymer capsule (fig. 1), wherein the elastomer core mainly acts as the resilient member and the

As we know, O-ring's major characteristic is the dependence $P = f(\epsilon)$, where P is force per unit of length, kg/cm, and ϵ is the relative compression strain across the ring's cross-section. Normally, this characteristic is determined experimentally. To find the main factors defining the dependence, the relation between the ring compressive force and the specified compression strain was studied at different values of rubber core hardness and capsule thickness. As figure 3 demonstrates, the per-unit force naturally increases proportionally to the strain. A thicker capsule and harder core also increase the force on the contact area. To assess the components' individual contribution into FRR behavior under strain, compressions of the capsule and the core have been studied separately.



d, D, t - specified dimensions

Figure 1. Fluoropolymer-encapsulated rubber ring

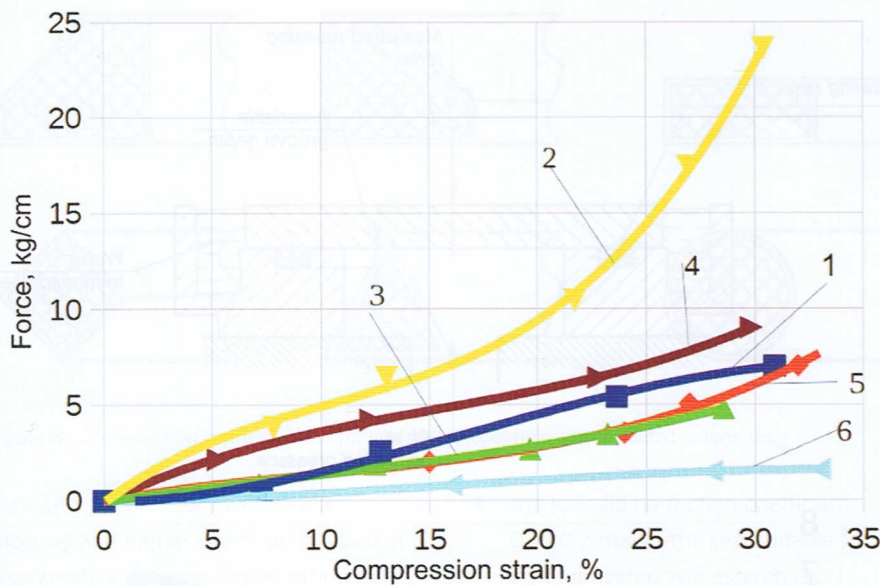

Figure 3. Per-unit force vs compression strain for encapsulated rings with a cross-section of 5.8mm and different rubber core hardnesses and capsule thicknesses: 1, 2 — core hardness Shor A 70; 3, 4 — core hardness Shor A 55; 1, 3 — capsule thickness 0.2 mm; 2, 4 — capsule thickness 0.7 mm; 5 — only core with hardness Shor A 60; 6 — only capsule with thickness 0.4 mm

Families of curves for different capsule thicknesses and different core hardnesses have been compared to find out that FRR stress-strain behavior is additively determined by the properties of constituent parts, i.e. the formula $P = f_1(\epsilon) + f_2(\epsilon)$ applies, where $f_1(\epsilon)$ is per-unit force dependence on compression strain for the capsule and $f_2(\epsilon)$ is the same for the rubber core. The dependence can be therefore drawn for all capsule/core combinations.

It has been demonstrated that FRR seals the gap due to the contact pressure generated by the force applied to the seal. For O-rings, the pressure is determined by the formula $p_c = P/(\pi Da)$, where a is contact area width and D is ring midline diameter. Contact area width a is a major parameter for two reasons. First, as aforesaid, the contact area width determines the contact pressure value. Moreover, the well-known cause of leaks from a sealed joint are the canals formed where two rough surfaces mate. It's the canals extending along the joint's entire width that cause the leaks. A wider contact is supposed and empirically proven to create a tighter seal at the joint and thus reduce the occurrence of the widthwise canals and consequently the leaks. Therefore, increasing the contact

width has two opposite effects: it reduces the contact pressure while enlarging the way for the fluid to penetrate through the contact.

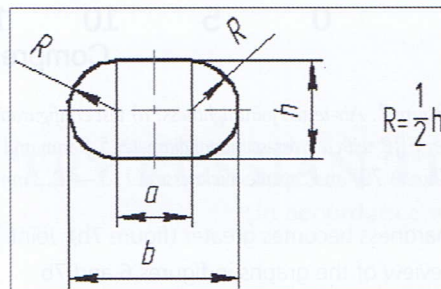

Figure 4. Contact area width calculation

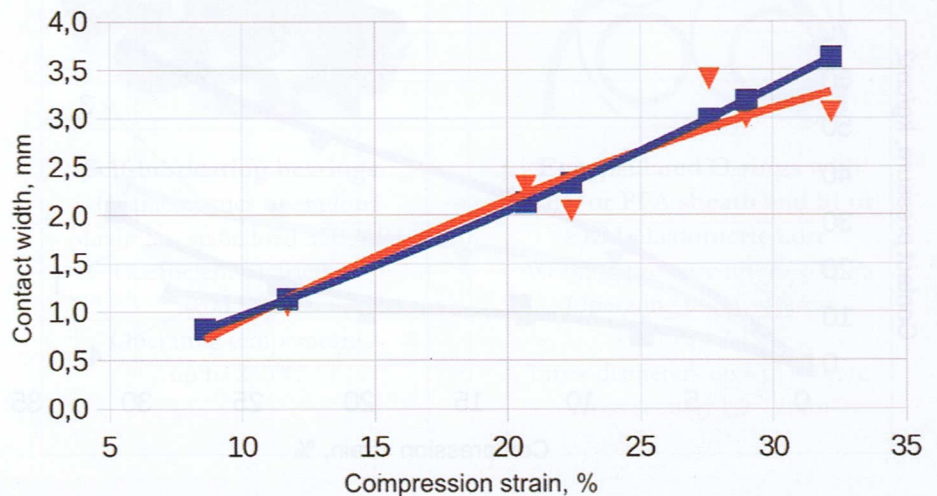

Figure 5. FRR contact area width at different compression strains. Calculation data - ■ vs experimental data - ▼.

Experiments have shown that the encapsulated O-ring, when compressed between two planes, forms a cross-section uniformly (radially) rounded on the sides (see fig. 4). Due to this we can theoretically calculate the contact area width from the ring compression strain. Given that the cross-section area remains constant throughout the strain, the formula is as follows:

$$a = (S - \pi R^2)/h = \pi(d^2 - h^2)/(4h)$$

where S is ring area, d is ring cross-sectional diameter and h is the compression strain, equal to the groove depth.

The contact area has been calculated after the formula: $F = \pi Da$, where D is ring midline diameter.

To check the calculation, the contact area width has been empirically verified at different compression strains on a transparent model with grooves of different depths. Figure 5 shows that the calculation data and experimental data match quite well, which allows using the dependence $P = f(\epsilon)$ to determine the contact pressure imposed by FRR. The principal consideration is that the contact width only depends on FRR geometry and has just negligible relation to rubber hardness or capsule thickness.

Thus, a greater compression strain gives a wider contact area, which must improve the tightness of the seal assembly. In this case, the contact pressure decreases, but, as shown below, this decrease is a minor influence compared with the improved tightness.

Contact pressures calculated for FRR with a cross-sectional diameter of 5.8 mm shown in figure 6 demonstrate that the contact pressure that increases proportionally to the ring strain can reach relatively high values, several times higher than with rubber seals. As we expected, the contact pressure becomes higher with thicker capsules and harder rubber cores.

The studies show that the strain-stress behavior of seals can be varied intentionally, but do not assess the seals' capacity to fill the gap between mating surfaces and prevent leaks. It is important to know how certain changes to the size and composition of FRR affect the ability to create a leak-proof connection. To obtain the knowledge, seal's properties influence on the sealing capacity has been investigated. The studies used the installation shown in figure 7a. Leak-tightness was assessed by the presence or absence of air leaks through the seal in the grooves of specified width under controlled external pressure.

The number and length of the canals are known to naturally decrease as the surface contact becomes closer under increasing pressing force; therefore, increase in ring compression strain and consequent growth in contact pressure must result in a tighter joint. The maximum pressure at which the joint remains tight is observed to increase as the ring compression strain increases and the ring

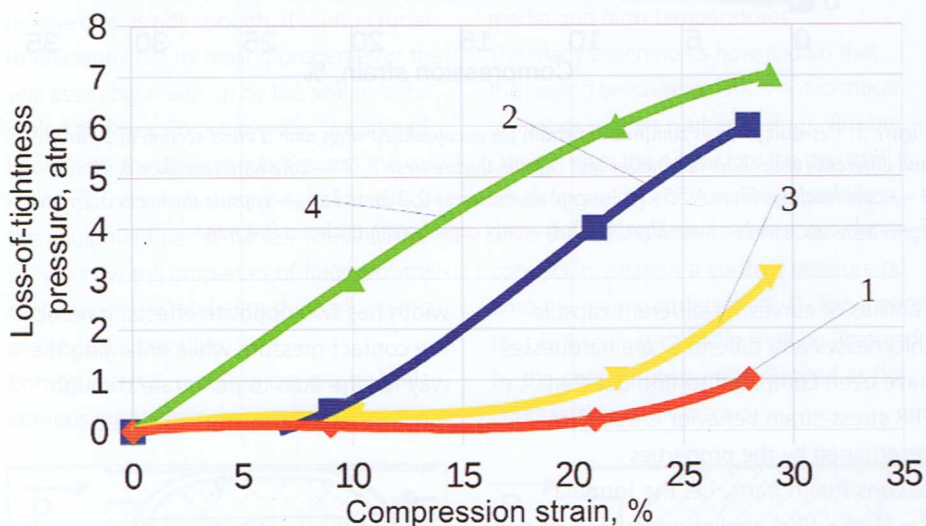
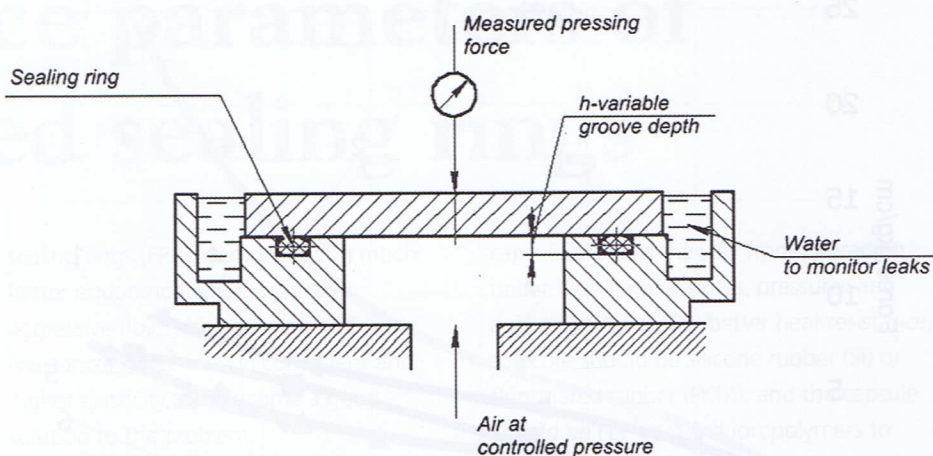

Figure 7. Air-tested joint tightness: a) test configuration; b) compression strain vs loss-of-tightness pressure for FRR with a cross-sectional diameter 5.8 mm and different core hardnesses (1, 2 — Shor A 55; 3, 4 — Shor A 70) and capsule thicknesses (1, 3 — 0.2 mm; 2, 4 — 0.7 mm).

hardness becomes greater (figure 7b). Joint review of the graphs in figures 6 and 7b shows the relation between the contact

pressure and the pressure at which the seal maintains its tightness in the air tightness test. Loss-of-tightness pressure to contact pressure ratio for the seal under review is ~ 10:1 with the given seal housing geometry. Evidently, with a more viscous fluid, e.g. water, this ratio will decrease. Thus, we can determine encapsulated ring tightness limits and use this knowledge to design intrinsically air-tight seal assemblies.

Encapsulated ring vendors recommend installing encapsulated rings in the grooves to be sealed by regular rubber O-rings. Our studies show that FRR grooves should be selected from different consideration but the subject is beyond the scope of this paper.

Fluoropolymer-encapsulated sealing rings can be configured as O-rings or have other configurations (fig. 8), which diversifies

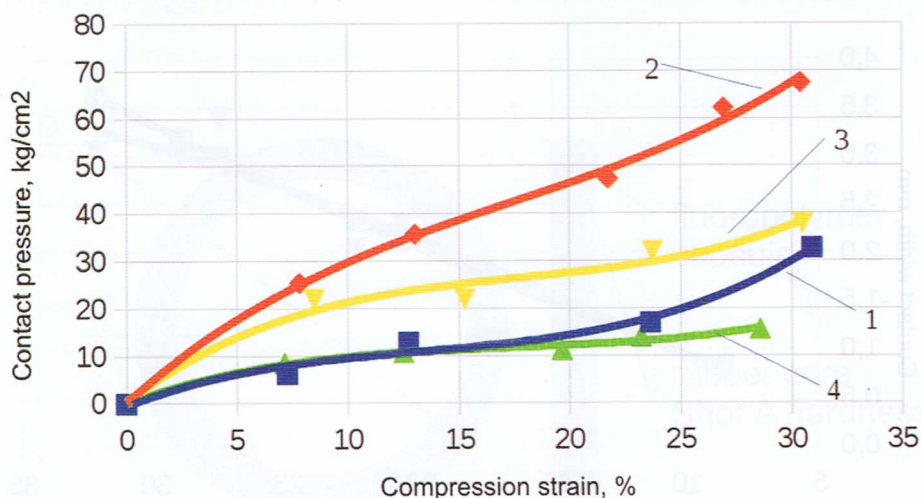

Figure 6. Contact pressure vs compression strain for encapsulated rings with a cross-sectional diameter of 5.8 mm and different core hardnesses and capsule thicknesses: 1, 2 — core hardness Shor A 70; 3, 4 — core hardness Shor A 55; 2, 3 - capsule thickness 0.7 mm; 1, 4 — capsule thickness 0.2 mm.

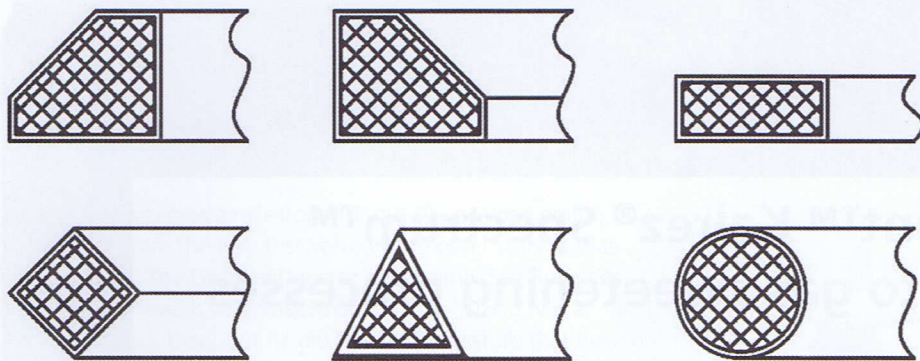

Figure 8. Cross-section configuration options for fluoropolymer-encapsulated sealing rings

their application. Seals with thicker capsules and harder cores can be used in heavy-duty assemblies experiencing rotary and reciprocating movements.

Major properties of fluoropolymer-encapsulated sealing rings:

1. unique chemical resistance to acid and alkali solutions, strong oxidizers, petroleum products and solvents;
2. operating pressures up to 100 MPa;
3. operating temperatures range from -200°C to +250°C;

4. the low sliding friction coefficient 0.1- 0.2 makes the seal suitable for non-lubricated seal assemblies;
5. gas tightness, non-swelling behavior in high-pressure fluids, no decompression effect;
6. elastic recovery from compression strain min. 90%.

Aforesaid properties make fluoropolymer-rubber rings suitable for such applications as end seals of pumps handling highly aggressive fluids, stop valve rod seals,

ball valve seat seals, packed covers and the casing joints exposed to extreme environmental conditions. Thus, the studies have succeeded in establishing the effects of the seal properties and its interaction with the mating equipment surfaces. Some relations have been found between the fluoropolymer-rubber ring properties and the performance of FRR-packed seal assemblies. We therefore can conclude that the potential of FRR increasing use in different types of equipment is quite high.

About the author

K. Yu. Zershchikov graduated from Volgograd State Polytechnic Institute in 1984 and later founded Constanta-2 in 1994, where he is currently General Director. The company produces seals and develops and manufactures valves. Mr. Zershchikov continues to conduct research work and has published many scientific articles in Russian journals. He also holds more than 10 patents for new seals and materials.



TRY RUSSIAN TECHNOLOGIES

(in accordance with ISO 3547)



Seals, ball seats from composite materials
“Konstafтор”®
 based on PTFE, PEEK, PPS, POM, UHMWPE.
 Operating temperatures:
 -190°C +300°C
 Maximum size — 1500mm



Self-lubricating bearings.
 Characteristics operation:
 Maximum static load 350 MPa
 Coefficient of friction
 0,05 - 0,1
 Operating temperature
 up to 250°C

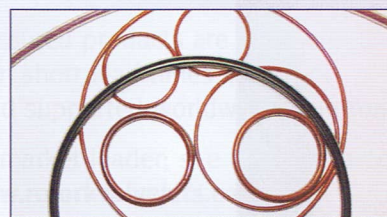

Encapsulated O-rings with FEP or PFA sheath and SI or FKM elastomeric core.
 Working pressure up to 40MPa
 Operating temperatures:
 -190°C +250°C
 Inner diameters up to 1500mm
 cross section 1,9-12mm

“Constanta-2”Ltd. Postal address: 400120, Volgograd, Po Box 2656 Office: 400120, Volgograd, Eliseeva str.3
 Tel.+78442 97 26 40, Fax +78442 94 55 56, E-mail: secret@constanta-2.ru, Web: www.constanta-2.ru